

# entrainment pump - series XV

EUROPEAN STANDARD DRIVING PUMP  
 ø25.4 FLANGE - TAPER SHAFT

X1T

**X 1 T 25 02 F I I A**

Series	X	series XV
Group	1	group 1
Category	T	entrainment pump
Displacement	25	3.8
Flange	02	Ø25.4 STANDARD EUROPEAN right rotation
Shaft	F	COP01 - Tapered 1:8 - ø10 - M7x1 - key thk.2.4
Body	IN	inlet - Ø30 Ø12 M6
	OUT	outlet - Ø30 Ø12 M6
Cover	A	ø25,5 female cover for left multiple pump element

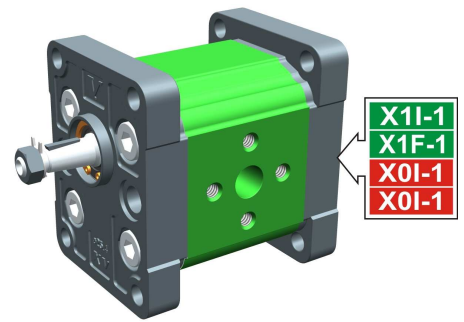

XT101

Technical data table

TYPE	Displacement cm3/rev	Max. Pressure		CODE	
		P1 bar	P3 bar	Left rotation	Right rotation
X1T/0.9	0,91	240	280	X 1 T 16 01 F I I A	X 1 T 16 02 F I I A
X1T/1.2	1,17	250	290	X 1 T 17 01 F I I A	X 1 T 17 02 F I I A
X1T/1.7	1,56	250	290	X 1 T 18 01 F I I A	X 1 T 18 02 F I I A
X1T/2.2	2,08	250	290	X 1 T 20 01 F I I A	X 1 T 20 02 F I I A
X1T/2.6	2,60	250	300	X 1 T 21 01 F I I A	X 1 T 21 02 F I I A
X1T/3.2	3,12	250	300	X 1 T 23 01 F I I A	X 1 T 23 02 F I I A
X1T/3.8	3,64	250	300	X 1 T 25 01 F I I A	X 1 T 25 02 F I I A
X1T/4.3	4,16	250	300	X 1 T 27 01 F I I A	X 1 T 27 02 F I I A
X1T/4.9	4,94	250	300	X 1 T 29 01 F I I A	X 1 T 29 02 F I I A
X1T/5.9	5,85	250	300	X 1 T 31 01 F I I A	X 1 T 31 02 F I I A
X1T/6.5	6,50	250	300	X 1 T 32 01 F I I A	X 1 T 32 02 F I I A
X1T/7.8	7,54	220	260	X 1 T 34 01 F I I A	X 1 T 34 02 F I I A
X1T/9.8	9,88	190	230	X 1 T 36 01 F I I A	X 1 T 36 02 F I I A

P1) Max. working pressure - P3) Max. peak pressure

For heavy-duty applications, it is recommended to check the admissible torque of the shaft

Dimensions table

TYPE	Weight kg	A mm	B mm	IN			OUT		
				D	E	F	D	E	F
X1T/0.9	0,950	74,5	37,3	ø12	30	M6x1	ø12	30	M6x1
X1T/1.2	0,970	75,5	37,8	ø12	30	M6x1	ø12	30	M6x1
X1T/1.7	1,010	77,0	38,5	ø12	30	M6x1	ø12	30	M6x1
X1T/2.2	1,030	79,0	39,5	ø12	30	M6x1	ø12	30	M6x1
X1T/2.6	1,060	81,0	40,5	ø12	30	M6x1	ø12	30	M6x1
X1T/3.2	1,090	83,0	41,5	ø12	30	M6x1	ø12	30	M6x1
X1T/3.8	1,120	85,0	42,5	ø12	30	M6x1	ø12	30	M6x1
X1T/4.3	1,170	87,0	43,5	ø12	30	M6x1	ø12	30	M6x1
X1T/4.9	1,200	90,0	45,0	ø12	30	M6x1	ø12	30	M6x1
X1T/5.9	1,260	93,5	46,8	ø12	30	M6x1	ø12	30	M6x1
X1T/6.5	1,300	96,0	48,0	ø12	30	M6x1	ø12	30	M6x1
X1T/7.8	1,360	100,0	50,0	ø12	30	M6x1	ø12	30	M6x1
X1T/9.8	1,500	109,0	54,5	ø12	30	M6x1	ø12	30	M6x1

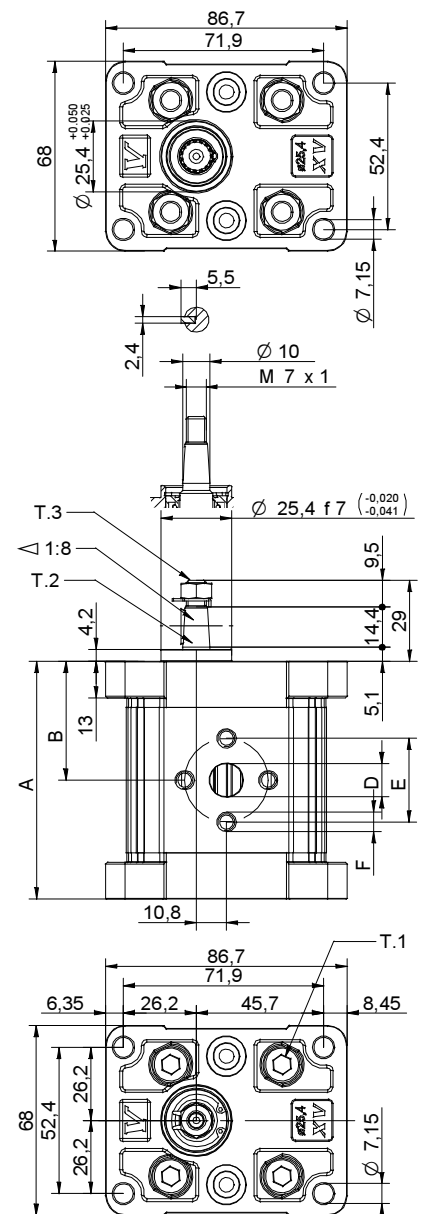

0104/08 X1T2502FIIA.dft

T.1 = 24.5÷29.4 [Nm] - screw tightening torque M8

T.2 = 43.1 [Nm] - admissible shaft torque (N.B. When choosing a shaft, always check the admissible torque).

# Table of variations

**X1T**

## ø25.4 FLANGE

ø25.4 FLANGE				Shaft				Cover		
Left rotation		Right rotation						Left rotation	Right rotation	
	<b>01</b>		<b>02</b>	<b>COP01 - Tapered</b> T.2 = 43.1 [Nm] 	<b>F</b>	<b>CFP02 - Milled shank</b> T.2 = 13.8 [Nm] 	<b>D</b>			<b>A</b>
	<b>03</b>		<b>04</b>	<b>SCP04 - Splined</b> T.2 = 22.6 [Nm] m=1.6 Z=6 DIN 5482 - 12x9 	<b>J</b>	<b>SCF02 - Splined</b> T.2 = 42.8 [Nm] m=0.75 Z=15 	<b>L</b>			<b>D</b>
	<b>05</b>		<b>06</b>	<b>SCF01 - Splined</b> T.2 = 42.8 [Nm] m=0.75 Z=15 	<b>Q</b>	<b>SCF03 - Splined</b> T.2 = 42.8 [Nm] m=0.75 Z=15 	<b>R</b>			
	<b>07</b>		<b>08</b>							

Displacement	
TYPE	CODE
X1T/0.9	<b>16</b>
X1T/1.2	<b>17</b>
X1T/1.7	<b>18</b>
X1T/2.2	<b>20</b>
X1T/2.6	<b>21</b>
X1T/3.2	<b>23</b>
X1T/3.8	<b>25</b>
X1T/4.3	<b>27</b>
X1T/4.9	<b>29</b>
X1T/5.9	<b>31</b>
X1T/6.5	<b>32</b>
X1T/7.8	<b>34</b>
X1T/9.8	<b>36</b>

Standard bodies							
Displacement cm3/rev	Standard threads						
	0.9	I - I	B - B	J - J	B - Z	Z - Z	G - F
1.2	I - I	B - B	J - J	B - Z	Z - Z	G - F	
1.7	I - I	B - B	J - J	B - Z	Z - Z	G - F	
2.2	I - I	B - B	J - J	B - Z	Z - Z	G - F	
2.6	I - I	B - B	J - J	B - Z	Z - Z	G - F	
3.2	I - I	B - B	J - J	B - Z	Z - Z	G - F	
3.8	I - I	B - B	J - J	B - Z	Z - Z	G - F	
4.3	I - I	B - B	J - J	B - Z	Z - Z	G - F	
4.9	I - I	B - B	J - J	B - Z	Z - Z	G - F	
5.9	I - I	B - B	J - J	B - Z	Z - Z	G - F	
6.5	I - I	B - B	J - J	B - Z	Z - Z	G - F	
7.8	I - I	B - B	J - J	B - Z	Z - Z	G - F	
9.8	I - I	B - B	J - J	B - Z	Z - Z	G - F	

Table showing standard flange and thread combinations available in stock

Body (threads/flanges)													
	<b>A</b>		<b>B</b>		<b>C</b>		<b>D</b>		<b>E</b>		<b>F</b>		<b>G</b>
	<b>H</b>		<b>I</b>		<b>J</b>	<b>Closed Body</b>	<b>Z</b>						